

PERFORMANCE OF REDUCED BEAM SECTION IN CASTELLATED BEAM SUBJECTED TO CYCLIC LOADING

by A. Arwin Amiruddin Teknik Sipil Unhas

Submission date: 20-May-2022 05:11AM (UTC-0500)

Submission ID: 1840528467

File name: 13_9_17.docx (276.62K)

Word count: 3047

Character count: 15797

PERFORMANCE OF REDUCED BEAM SECTION IN CASTELLATED BEAM SUBJECTED TO CYCLIC LOADING

NINI HASRIYANI ASWAD^{1,*}, HERMAN PARUNG², RITA IRMAWATY²,
A. ARWIN AMIRUDDIN²

¹Student at Doctoral Program in Civil Engineering, Universitas Hasanuddin,
Jl. Poros Malino km. 6, Kampus Teknik Gowa, Indonesia

²Lecturer at Department of Civil Engineering, Universitas Hasanuddin,
Jl. Poros Malino km. 6, Kampus Teknik Gowa, Indonesia

*Corresponding Author: niniaswad@gmail.com

Abstract

The study used an experimental test to analyse the performance of Reduced Beam Section (RBS) on castellated beam column with exterior connection structure model subjected to cyclic load gradually until collapse. The study used two specimens, which were models with and without RBS. The experiment was aimed to evaluate the performance of castellated beam structure with and without RBS affected by the position of castellated beam opening and RBS position on the beam-to-column connection. The results show that the maximum drift ratios of the specimens without RBS (WRBSC) and RBSC-1 were 3.2% and 3.15%, respectively. Meanwhile, the respective ductility performance was 2.45 and 2.56 while the respective stiffness was 0.09 and 0.08.

Keywords: Castellated beam, Cyclic load, Drift ratio, RBS.

1. Introduction

Seismic design for steel moment frame is aimed to make structure elastic during small to medium seismic events. In large earthquakes, the structure must be strong and secure from collapse. In the 1994 Northridge earthquake, fractures occurred on the connections, which some of them often started at the bottom flange weld and spread to the column flange and the beam web [1]. Miller [2] reported that the crack model on the Northridge Earthquake began at the point of intersection between the weld access hole and the beam bottom flange. Nakashima et al. [3] in the 1995 Kobe Earthquake, described that many fractures were found in beam-to-column welded connections. The fractures were caused by metal welding, heat-affected zones, base metals, and diaphragm plates. Most of the fractures were situated on the lower beam flanges.

Chen et al. [4] explain that a single lengthened rib can be used as a fortification to prevent damage to the beam groove weld. The rib extension reduces the pressure concentration, prevents fractures across the beam flange at the rib end and generates the desired plastic hinge at the beam section at a distance from the column face. The results show that the single lengthened rib show a reliable ductility to maintain the desired inelastic deformation with no brittle fracture, and it generates 3% radians of plastic rotation.

Jones et al. [5] and Zekioglu et al. [6] tested three connections, comprised of a Reduced Beam Section (RBS) with two triangular rib plates welded to each beam flange. These studies develop high beam plastic rotation capacities with considerable flexural strength. They found identical results at the three connections, where a failure occurred on the reduced beam section. The triangular rib plates help reduce stresses of groove welds between the beam and column flanges, with no failure observed in the triangular rib plates.

Tonapa et al. [7] conducted a study with the variation of opening angle and distance with 0.6 H opening height subjected to monotonic loading. Profile of solid steel fabricated to a castellated beam was IWF 200 100 5.5 8. The results show that the best opening angle and length were of hexagonal opening were 60° and $e = 9$ cm, respectively.

Plumier [8] originally introduced and tested the idea of a Reduced Beam Section (RBS). The RBS is also known as the 'dog bone' connection. Iwankiw [9] and Chen et al. [10] proposed and tested two primary types of RBS, which are tapered flange and the linear segment.

The objective of the RBS is to reduce the beam stiffness, which consequently reinforces the connection to mitigate damage and fracture in the welded joint between the beam and column flanges. The analysis of the experimental results [11] has confirmed the behaviour and performance of beam-to-column connection with RBS. In RBS connection, parts of the beam flange are trimmed at a specified distance from the face of the column to develop plastic hinge at the desired area. The RBS connection is very strategic in plastic mechanism in the desired area of the beam.

Uang et al. [12] explained that the tested specimens with RBS had failures on the RBS area with no failure occurred on beam-to-column welded connection. The study also reported a 3% radian plastic rotation on the beam with RBS [12].

Trimming the flange delays the local buckling, but it increases the possibility of web buckling and lateral-torsional buckling due to the decreased flange stiffness. In a theoretical model developed with a finite element model, when the results were compared with the obtained results of an experimental study, the specimen without RBS displayed fracture originated from bottom flange weld. Meanwhile, the RBS specimen had no damage on welding connections with the rotation capacity of 0.02 radian [13].

The joint should have adequate strength and stiffener to resist the internal force induced by the framing members and external force like earthquake and wind loading [14].

Sindhi et al. [15] compared the behaviour of buildings with RBS and conventional buildings and found that there were 23% deflection increase and the drift ratio improvement on the upper level of the buildings. Many experimental studies and literature reviews of castellated beam and RBS have been conducted. Chambers et al. [16] state that the RBS connection had decreased strength compared to the connection without RBS due to the trimming of the flange, in a study of exterior connection of beam-column joint subjected to cyclic loads. Sungkono [17] meanwhile explains that beam with RBS experienced failure caused by bending on the beam. In the study, the top of the beam had a maximum tensile while the bottom of the beam had compressive stress. Moreover, the shear stress on the beam web was larger than on the beam flange. Meanwhile, our study analyzed the comparison between castellated beam joints with and without RBS connection. The engineering design process was done to consider, detail and assess the steel frame construction by moving the plastic joint area of the beam away from the column face, either by locally reinforcing the beam joint to the column or by reducing the beam stress to the joint to reduce the stress in the beam area at a specific distance from the column face.

RBS technique on castellated beam has an ability to created plastic moment far from the face without significance of strength loss. Maximum load and maximum displacement were not significant for RBS and without RBS [11].

2. Reduced Beam Section (RBS)

Reduced Beam Section (RBS) is a modification of the beam cross-section by trimming the flange at a specified distance from the column face. The reduction was made in a way that all melting and plastic joint occurred in the RBS. Moreover, the trimmed area also could reduce the moment on the column and control the inelastic deformation of the column. The RBS design is regulated in AISC 358-16 standards [18]. According to AISC 358-16 subchapter 5.8, the procedure of designing RBS is as follows.

Determination of RBS geometry (Fig. 1) is limited by:

$$0.5b_f < a < 0.75b_f \quad (1)$$

$$0.65d < b < 0.85d \quad (2)$$

$$0.1b_f < c < 0.25b_f \quad (3)$$

with:
 b_f = width of beam flange
 d = depth of the beam

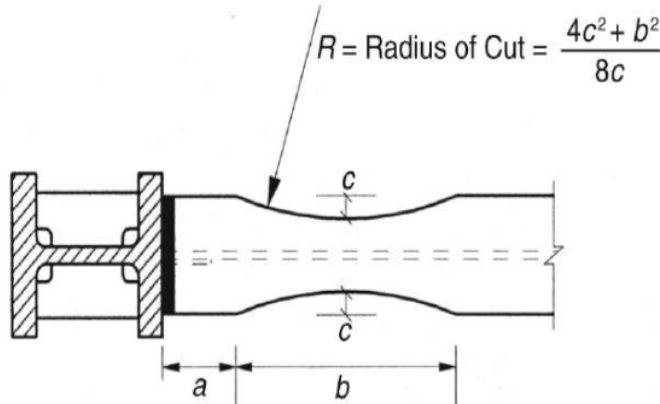

Fig. 1. RBS design on beam flange.

3. Method

3.1. Experimental Testing

The study aimed to analyse the performance of a structure by making the model of the exterior castellated beam with RBS connection and formulating the placement of the plastic hinge on the beam using the Reduced Beam Section (RBS) method based on the strong column-weak beam principle. The model was tested experimentally to obtain the formulation of castellated beam distance to RBS from the column face. The specimens were investigated by analysing the strength and structure of ductility in earthquake resistance.

The study used RBS of the castellated beam to obtain the result of the experimental test or simulation on the exterior structure and beam-column joints. Manual analysis of the strength of the design was done on the RBS column beam model to analyze the strength and drift ratio of the cyclic lateral load. The identified parameters were strength, stiffness, ductility, and drift ratio. The tensile test material used is BJ 37 as shown in Table 1.

Two tested beams in this study were the castellated steel beam without RBS (WRBSC) and the castellated steel beam with RBS model 1 (RBSC-1), with the specified dimension, is displayed in Fig. 2. Meanwhile, detail of the tested beam dimension is described in Table 2. The testing was designed with a strong column assumption according to seismic regulations as the requirement of designing earthquake-resistant structures [18].

Table 1. Characteristic of tested beam.

Tested beam	Castellated dimension (mm)				f_y (MPa)	f_u (MPa)
	Flange width	Web depth	t_f	t_w		
WRBSC	75	225	7	5	357	455
RBSC-1	75	225	7	5	357	455

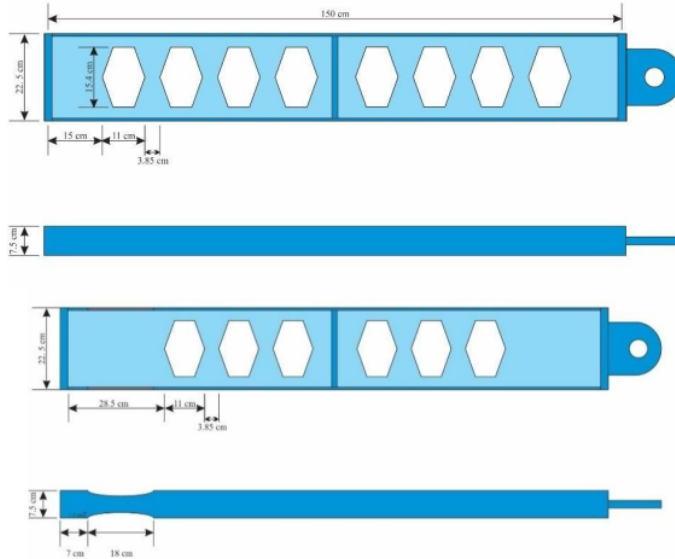

Fig. 2. The dimension of castellated beam and RBS.

Table 2. The dimension of the tested beam.

Tested beam	Castellated opening distance from the column face (mm)	Distance of trim (RBS) from the column face (mm)
WRBSC	150	-
RBSC-1	285	70

3.2. Experimental Design

The study was conducted to analyze the behaviour of RBS castellated column, which was used to examine whether the specimen was more economical than other methods. The welding procedure was done on the system considered as a semi-rigid connection. The testing set-up displayed in Fig. 3. Loading was exerted by applying a cyclic load. In the tests, lateral support near the actuator was provided to prevent lateral deformation of the beam and damage of the actuator. The global

1 deformation of the specimen was measured during the test to determine the deformation and deflection components of the beam.



Fig. 3. Experimental set-up.

The study to obtain records of a structure experiencing a force due to cyclic loading to reach the melting or plastic limit was done in four stages; namely, the tested structure design was modelled by the exterior column beam with cyclic load, the test results of the structure was read using an accelerometer and recorded into the computer. The cyclic loading was applied gradually with a hydraulic jack and load cell according to the value of displacement at the first melting point (Δy). The displacement (melting point) was determined for each cycle in $0.25\Delta y$, $0.5\Delta y$, $0.75\Delta y$, Δy , $2\Delta y$, $3\Delta y$ and so on until the load termination in case of decreased load value from the previous peak (collapse) [19]. The history of the load cycle is displayed in Fig. 4.

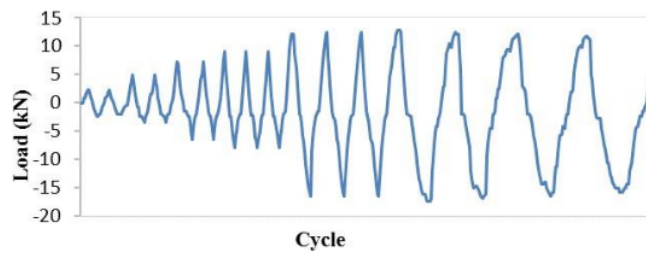

Fig. 4. History of the load cycle.

4. Results and Discussion

In our study, all tested beams experienced failure due to bending on the beam caused by the first melt on the beam flange. Table 3 shows the obtained maximum load. In our study, the detail of the failure on the beams explained the effect and cause of failure classified by each tested beam. The results show that the maximum loads of the WRBSC and RBSC-1 were 12.5 kN and 12.05 kN, respectively. This means that the WRBS beam had 4% more strength to withstand larger load compared to the RBS beam.

The experimental results show that failure occurred on the column face due to the pure bending of the beam, no failure occurred on beam-to-column connection, and the ductility of the castellated beam structure reached 4.1 on cyclic load [20]. Performance of tested beams is shown in Table 3. The partial ductility (load capacity) of RBSC-1 was higher than WRBSC, with the respective number reached 87.5% to 87%.

As can be seen in Table 3, the average ductility of the beam with RBS was 10% higher than the conventional beam without RBS. On the contrary, the stiffness of RBS beam was 1% lower than WRBSC. Figure 5 illustrates the strength of peak lateral load occurred in ratio drift on both tested beams.

As shown in Fig. 5, the maximum melting point occurred at 12 kN positive load (push). Figure 5 also displays the backbone of the relation between load and displacement and the maximum load on displacement. Figures 6 and 7 show the hysteresis curve of beams subjected to the cyclic load. In Figs. 6 and 7, the lateral load capacity increased as the lateral displacement rose. The difference between positive and negative maximum loads was possible due to the different movement of load cell pads to each side that affected the lateral deflection of the beam.

Figures 8 and 9 show the damage in the flange of beams without RBS and with RBS, respectively. As can be seen in Fig. 8, in the beam without RBS, there was no stress concentrated on the column face. Meanwhile, Fig. 9 displays that the damage was concentrated in the RBS area.

Table 3. The experimental results of tested beams.

Test Result	WRBSC	RBSC-1
Ductility (μ^+)	1.78	1.97
Ductility (μ^-)	3.12	3.15
Stiffness	0,09	0,08
Maximum push load, P (kN)	12.5	12.0
Maximum pull load, P' (kN)	16,6	12,5
Maximum push load before collapsing, P^+ (kN)	10.9	10.2
Maximum pull load before collapsing, P'^- (kN)	14.3	11.4
Ratio to peak load (+) P/P^+	88 %	85 %
Ratio to peak load (-) P'/P'^-	86 %	90 %

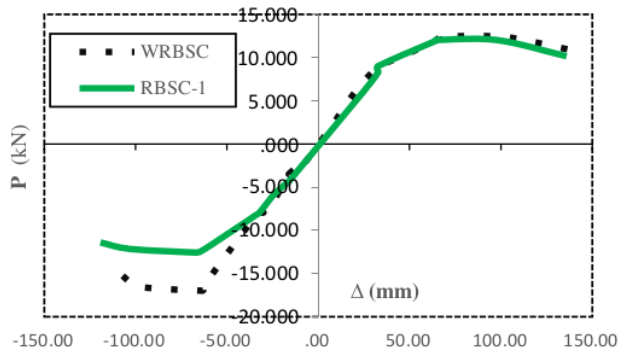

Fig. 5. The relation between load and displacement.

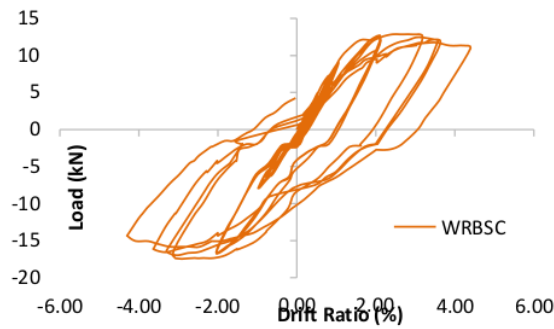

Fig. 6. Hysteresis of WRBSC tested beams.

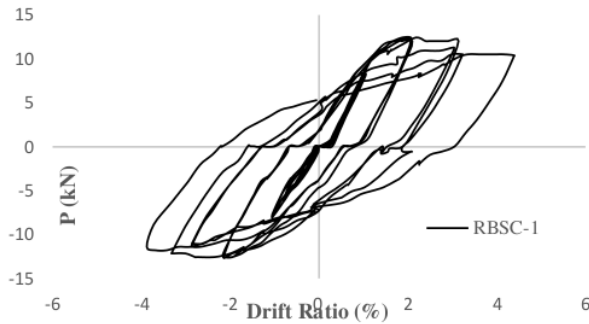

Fig. 7. Hysteresis of RBSC-1 tested beams.



Fig. 8. Damage on WRBSC beam flange.



Fig. 9. Damage on RBSC-1 beam flange.

5. Conclusions

Some concluding observations from the investigation are given below.

- The results show that the hysteresis curve had a higher magnitude on the negative force than the positive. The strength ratio of the cyclic load in both directions on WRBSC and RBSC-1 were 87% and 87.5%, respectively.
- The drift ratio of maximum lateral load capacity on WRBSC, RBSC-1 reached 3.2 % drift ration on 12.5 kN load and 3.15 % on 12 kN load. The bending failure occurred first on the positive drift than the negative.
- The ductility performance of RBSC was higher than WRBSC. However, the stiffness of RBSC was lower than WRBSC.

Nomenclatures

a	The horizontal distance from the face of column flange to start of an RBS cut, mm
b	Length of an RBS cut, mm
b_f	The width of beam flange, mm
d	The depth of beam, mm
e	Length of hexagonal opening on castellated, cm
f_u	The ultimate strength of steel, MPa
f_y	The yield strength of steel, MPa
P	Maximum lateral force, kN
P'	Maximum lateral force before the collapse, kN
t_f	The thickness of beam flange, mm
t_w	The thickness of web-flange, mm

Greek Symbols

Δy	Displacement of the first yield, mm
μ^+	Ductility of push load
μ^-	Ductility of pull load

Abbreviations

AISC	American Institute of Steel Construction
BJ	Indonesian Steel Quality
IWF	Properties of Steel
RBS	Reduced Beam Sections
RBSC	Reduced Beam Sections with Castellated
WRBSC	Without Reduced Beam Sections

References

1. SAC Joint Venture. (1995). Interim guidelines: Evaluation, repair, modification and design of steel moment frames. *Report no. SAC-95-02*, Sacramento, California.
2. Miller, D.K. (1998). Lessons learned from the Northridge earthquake. *Engineering Structures*, 20(4-6), 249-260.
3. Nakashima, M.; Inoue, K.; and Tada, M. (1998). Classification of damage to steel buildings observed in the 1995 Hyogoken-Nanbu earthquake. *Engineering Structures*, 20(4-6), 271-281.
4. Chen, C.-C.; Lee, J.-M.; and Lin, M.-C. (2003). Behavior of steel moment connections with a single flange rib. *Engineering Structures*, 25(11), 1419-1428.
5. Jones, S.L.; Fry, G.T.; and Engelhardt, M.D. (2002). Reduced beam section welded steel moment frames. *Proceedings of the 12th World Conference of Earthquake Engineering (12WCEE 2000)*. Auckland, New Zealand, 8 pages.
6. Zekioglu, A.; Mozaffarian, H.; Chang, K.L; Uang, C.M; and Noel S. (1997). Designing after Northridge. *Modern Steel Construction*, 37(3), 36-42.
7. Tonapa, S.R.; Sandy, D.; and Parung H. (2015). Behavior of castellated composite beam-columns subjected to monotonic and cyclic loadings. *International Journal of Engineering and Science Applications*, 2(2), 147-152.
8. Plumier, A. (1997). The dog-bone: Back to future. *Engineering Journal*, 34(2), 61-67.
9. Iwankiw, N.R. (1997). Ultimate strength consideration for seismic design of the reduced beam section (internal plastic hinge). *Engineering Journal*, American Institute of Steel Construction, 34(1), 3-16.
10. Chen, S.J.; Yeh, C.H.; and Chu, J.M. (1996). Ductile steelbeam-to-column connections for seismic resistance. *Journal of Structural Engineering*, 122(11), 1292-1299.
11. Aswad, N.H.; Parung, H.; Irmawaty, R.; and Amiruddin, A.A. (2017). The effect of reduced beam section on castellated beam. *Proceedings of the 6th International of Euro Asia Civil Engineering Forum (EACEF 2017)*. Seoul, Korea, 7 Pages.
12. Uang, C.M.; Yu, Q.S.; and Gilton, C.S. (2000). Effects of loading history on cyclic performance of steel RBS moment connections. *Proceedings of the 12th World Conference of Earthquake Engineering (12WCEE 2000)*. Auckland, New Zealand, 8 pages.

13. Swati, A.K.; and Veswamala, G.R. (2014). Study of steel moment connection with and without reduced beam section. *Case Study in Structural Engineering*, 1(1), 26-31.
14. Vahid, S.Z.; Osman, S.A.; and Khalim, A.R. (2013). Monotonic and cyclic loading simulation of structural steelwork beam to column bolted connection with castellated beam. *Journal of Engineering Science and Technology (JESTEC)*, 8(4), 416-427.
15. Sindhi, N.R.; Gadhiya, J.A.; and Dhameliya, H.K. (2016). Study of steel moment resisting frame with reduced beam section. *Journal of Engineering Research and Applications*, 6(5), 43-47.
16. Chambers, J.J.; Almudhafar, S.; Stenger, F. (2003). Effect of reduced beam section frame elements on stiffness of moment frames. *Journal of Structural Engineering*, 129(3), 383-393.
17. Sungkono, K.K.D. (2017). Stress analysis of reduced beam section steel moment connection. *e-Journal Teknik Sipil dan Arsitektur Fakultas Teknik UTP Surakarta*, 21(25), 12 pages.
18. American Institute of Steel Construction. (2010). Prequalified connections for special and intermediate steel moment frames for seismic applications. *An American National Standard, ANSI/AISC 358-16*, 284 pages.
19. Krawinkler, H. (1992). *Guidelines for cyclic seismic testing of components of steel structures*. Redwood City, California: Applied Technology Council.
20. Aswad, N.H.; Parung, H.; Irmawaty, R.; and Amiruddin, A.A. (2017). Evaluasi posisi jarak bukaan balok kastella terhadap daktilitas. *Prosiding Konferensi Nasional Teknik Sipil 11*. Jakarta, Indonesia, 91-99.

PERFORMANCE OF REDUCED BEAM SECTION IN CASTELLATED BEAM SUBJECTED TO CYCLIC LOADING

ORIGINALITY REPORT

7%

SIMILARITY INDEX

0%

INTERNET SOURCES

7%

PUBLICATIONS

0%

STUDENT PAPERS

PRIMARY SOURCES

1

Chen, C.C.. "Behaviour of steel moment connections with a single flange rib",
Engineering Structures, 200309

Publication

7%

Exclude quotes On

Exclude matches < 5%

Exclude bibliography On

PERFORMANCE OF REDUCED BEAM SECTION IN CASTELLATED BEAM SUBJECTED TO CYCLIC LOADING

GRADEMARK REPORT

FINAL GRADE

/0

GENERAL COMMENTS

Instructor

PAGE 1

PAGE 2

PAGE 3

PAGE 4

PAGE 5

PAGE 6

PAGE 7

PAGE 8

PAGE 9

PAGE 10

PAGE 11
